

Date	Revision	Description	AUTH	DR	CK

Heavy Adjustment Kit 1 2 3 4
CA-0063

Light Adjustment Kit 1 2 3 4
CA-0062

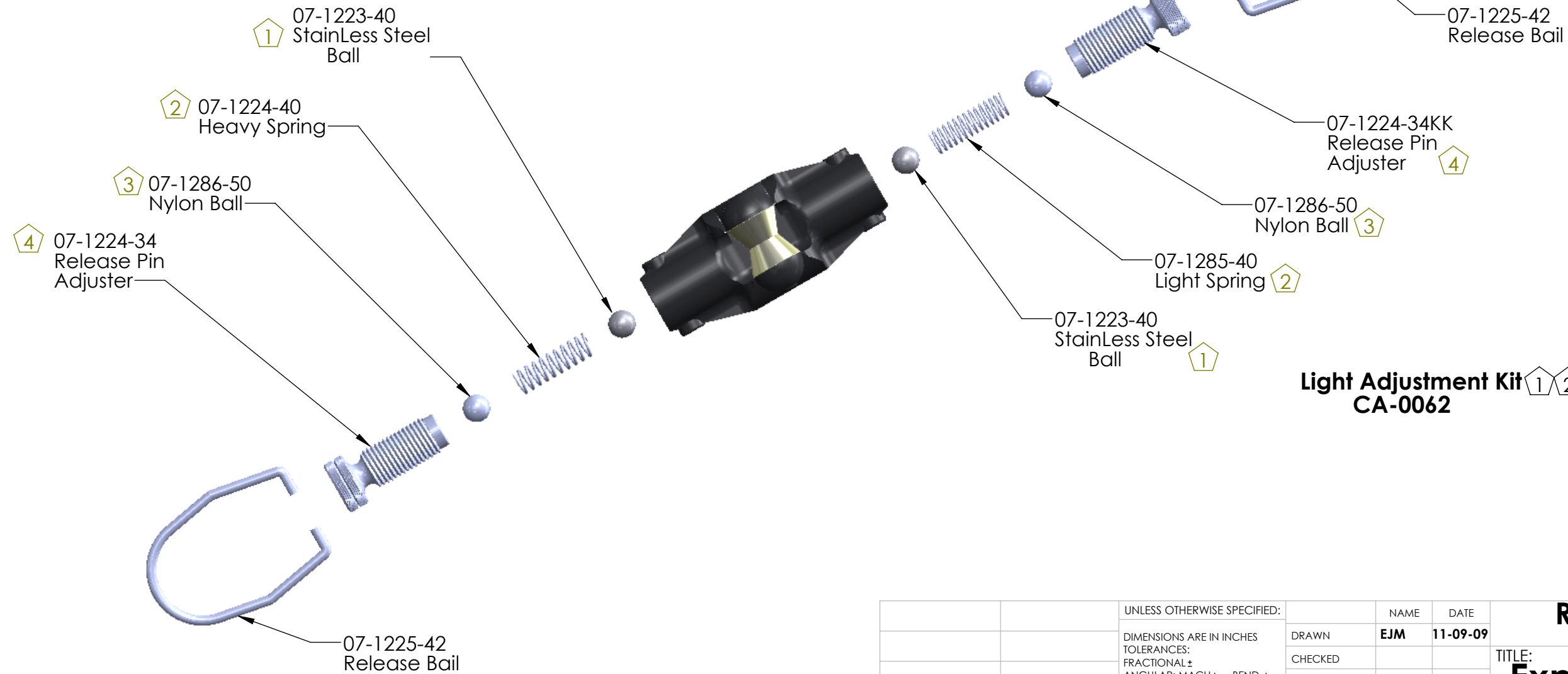

PROPRIETARY AND CONFIDENTIAL
THE INFORMATION CONTAINED IN THIS DRAWING IS THE SOLE PROPERTY OF <INSERT COMPANY NAME HERE>. ANY REPRODUCTION IN PART OR AS A WHOLE WITHOUT THE WRITTEN PERMISSION OF <INSERT COMPANY NAME HERE> IS PROHIBITED.

UNLESS OTHERWISE SPECIFIED:		NAME	DATE	Rupp Marine Port Salerno, FL.	
DIMENSIONS ARE IN INCHES TOLERANCES: FRACTIONAL ± ANGULAR: MACH ± BEND ± TWO PLACE DECIMAL ± THREE PLACE DECIMAL ±		DRAWN	EJM		
INTERPRET GEOMETRIC TOLERANCING PER:		CHECKED	TITLE:		Exploded View Nok-Out[®] Assy
MATERIAL		ENG APPR.	MFG APPR.		
FINISH		Q.A.	COMMENTS:		SIZE
NEXT ASSY	USED ON	DO NOT SCALE DRAWING		SCALE: None	DWG. NO. CA-0023
APPLICATION		DO NOT SCALE DRAWING		REV NC	
				SHEET 1 OF 1	